SECTION 11110**PERSONAL PROTECTION EQUIPMENT (PPE) DRYING CABINET****PART 1 GENERAL**

1.01 SECTION INCLUDES:

- A. Automatic drying cabinet for processing water-washed personal protection equipment

1.02 SYSTEM DESCRIPTION

A. DESIGN REQUIREMENTS:

- 1. Dry capacity: 5 full sets of PPE
- 2. Cabinet volume: 66 cu ft (1868912 cu cm) minimum
- 3. Construction: Heavy duty embossed steel with baked enamel powder paint.
- 4. Input voltage: 240/60/3
- 5. Heat source: Electric, 2 x 12 kW
- 6. Overall width: 55 1/8 inches (1400 mm) nominal
- 7. Overall depth: 30 13/16 inches (783 mm) nominal
- 8. Overall height: 81 1/2 inches (2070 mm) nominal
- 9. Exhaust size: 6 inch (153 mm)
- 10. Control system: Microprocessor touchpad control
- 11. Door: Painted steel, double doors with heavy duty hinges

B. PERFORMANCE REQUIREMENTS:

- 1. Airflow: 300 CFM (5.5 CMM)
- 2. Motor horsepower: 2 x 1/8 hp
- 3. Control system
 - a. Minimum of five programmable drying cycles
 - b. Ability to time dry up to 180 minutes
 - c. Ability to cool from 2 minutes to 60 minutes
 - d. Variable temperature settings from 100 - 110°F (38 - 43°C)

1.03 DELIVERY, STORAGE & HANDLING

A. ACCEPTANCE AT SITE:

- 1. Inspect machine for damage prior to acceptance. If damage is found, follow freight handler's procedure for claims.

B. STORAGE & PROTECTION

- 1. Machine should be stored in a site protected from weather, direct sunlight & temperature extremes. Do not remove packaging prior to storage.
- 2. If machine is to be stored for an extended period of time, consult manufacturer for special requirements.

1.04 WARRANTY

- A. Warranty Period: Limited one year, parts only, commencing on Date of Substantial completion

1.05 SYSTEM STARTUP & COMMISSIONING

- A. Machine installation should be inspected by local manufacturer's representative prior to startup & operation. The party installing the machine is responsible for setting the schedule for this inspection.

PART 2 PRODUCTS

- A. Source quality
- B. Alliance Laundry Systems LLC - UniMac, obtain commercial laundry equipment from a single manufacturer

1.02 QUALIFIED MODELS

- A. UniMac model **AGU65** (no substitutions permitted)

PART 3 EXECUTION

1.01 INSTALLATION

- A. Refer to & comply with manufacturer's installation instructions. Do not deviate without permission from site owner, architect, general contractor & manufacturer's local representative.

CABINET DIMENSIONS AND DRAIN CONNECTION LOCATIONS

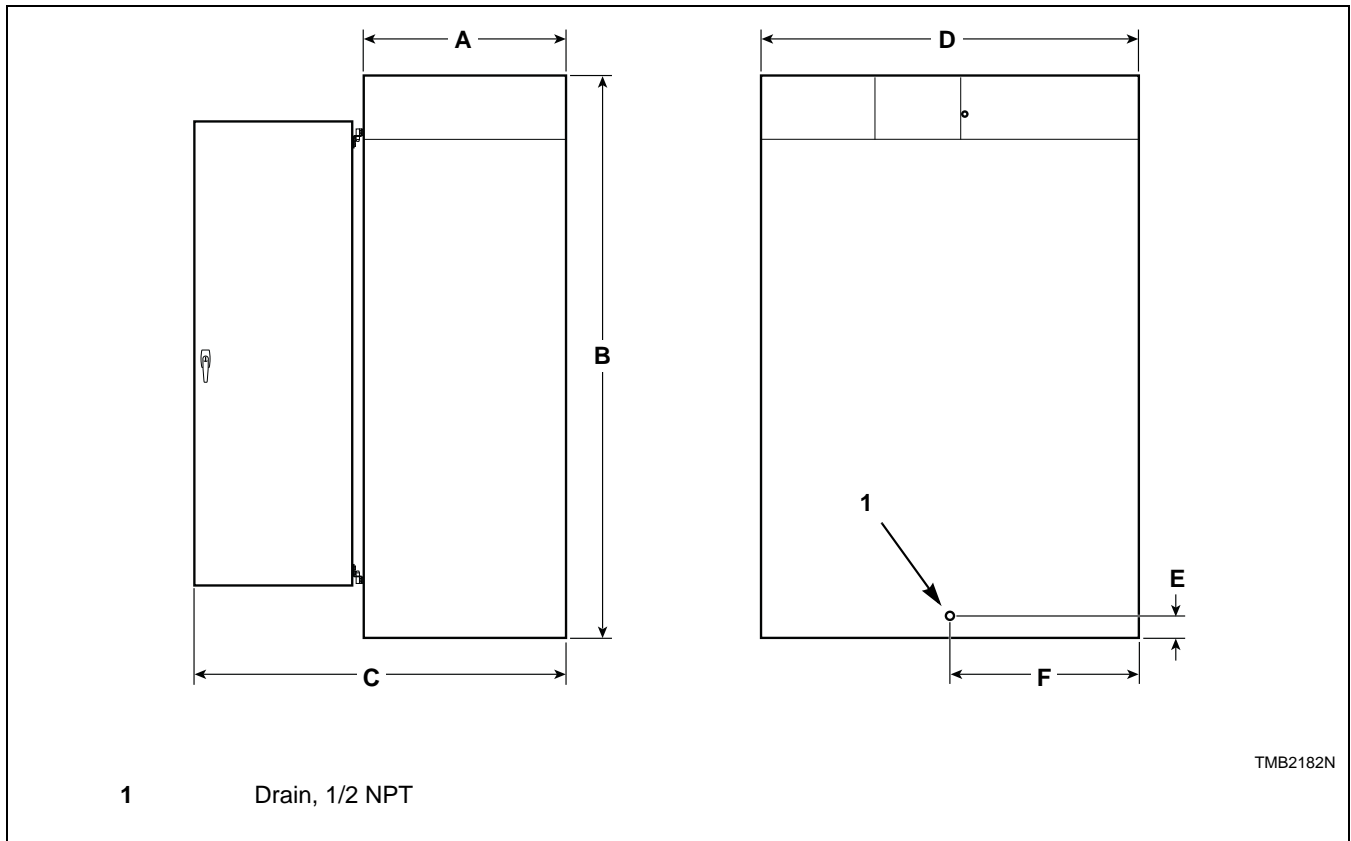

A	B	C	D	E	F
30.83 in. (783 mm)	81.5 in. (2070 mm)	54.81 in. (1392 mm)	55.13 in. (1400 mm)	1.5 in. (38.1 mm)	27.56 in. (700 mm)

NOTE: These figures are approximate dimensions only.

EXHAUST OUTLET AND ELECTRICAL CONNECTION LOCATIONS

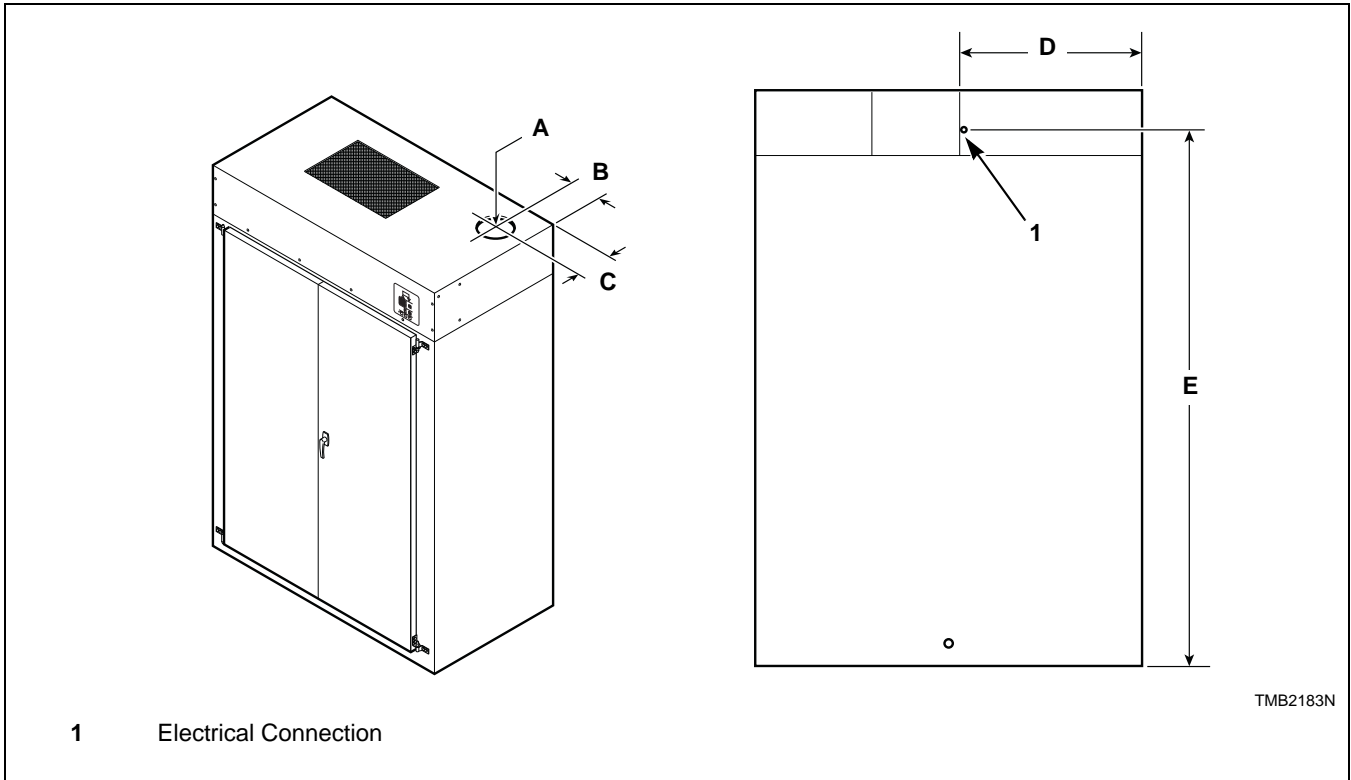

A	B	C	D	E
6 in. (152.4 mm)	8 in. (203.2 mm)	8.38 in. (212.85 mm)	25.88 in. (657.35 mm)	75.94 in. (1928.88 mm)

NOTE: These figures are approximate dimensions only.